



International Journal of Multidisciplinary Research in Science, Engineering and Technology

(A Monthly, Peer Reviewed, Refereed, Scholarly Indexed, Open Access Journal)



Impact Factor: 8.206

Volume 9, Issue 4, April 2026



International Journal of Multidisciplinary Research in Science, Engineering and Technology (IJMRSET)

(A Monthly, Peer Reviewed, Refereed, Scholarly Indexed, Open Access Journal)

AUTOBIN: Automated Waste Collection and Alert System

Yamuna S¹, Abinesh C², Devadharshini R³, Ezhilarasan M⁴ and Megamithra J⁵

Assistant Professor, Department of ECE, Adithya Institute of Technology, Coimbatore, Tamil Nadu India ¹

Student, Department of ECE, Adithya Institute of Technology, Coimbatore, Tamil Nadu India^{2,3,4,5}

ABSTRACT: This paper presents the design and implementation of a smart waste collection and automatic alert system aimed at improving waste management efficiency. Rapid urbanization has increased waste generation, making traditional collection methods inefficient. The proposed system uses ultrasonic sensors to detect garbage levels and load cells to measure weight. An Arduino UNO processes the data and transmits it using LoRa communication. At the receiver side, an ESP32 controller analyzes the data and triggers alerts through IoT platforms and buzzers. The system ensures timely waste collection, reduces overflow, and promotes a cleaner environment. This solution contributes to smart city development by integrating automation, wireless communication, and real-time monitoring.

KEYWORDS: Smart waste management, LoRa communication, Wireless monitoring, Smart city technology

I. INTRODUCTION

Waste management has become a major challenge in today's world due to rapid population growth and urbanization. The increasing amount of waste generated in cities leads to serious environmental and health problems. Improper disposal of garbage results in air pollution, soil contamination, and the spread of diseases. Traditional waste management systems rely on manual monitoring, which is inefficient and often leads to overflowing bins.

This creates unhygienic conditions and affects public health. To overcome these issues, smart and automated solutions are required. Autobin is a smart waste management system designed to improve the efficiency of garbage collection. It uses sensors and microcontrollers to monitor the level of waste in real time. An ultrasonic sensor detects the fill level of the bin and sends the data for processing. When the bin reaches its maximum capacity, an alert is sent to the concerned authorities. This helps in timely collection of waste and prevents overflow.

The system also reduces manual effort and saves time, fuel, and manpower. In addition, features like automatic lid opening improve hygiene by reducing human contact. Autobin supports the concept of smart cities by ensuring clean and organized waste disposal. It also contributes to environmental protection and sustainable development. Overall, the system provides an efficient, reliable, and eco-friendly solution for modern waste management.

II. LITERATURE SURVEY

Waste management has become a critical challenge due to rapid urbanization and population growth, resulting in increased waste generation. Traditional waste collection systems are inefficient as they rely on manual monitoring, leading to issues such as overflowing bins, environmental pollution, and health hazards. To address these challenges, researchers have focused on developing smart waste management systems using advanced technologies like the Internet of Things (IoT), sensors, and automation.

[10] Labade et al. shows that the system uses sensors to detect the garbage level in bins. It provides real-time monitoring and reduces overflow issues. Data is sent to authorities for timely collection. This improves cleanliness and efficiency in waste management. [16] This paper focuses on detecting garbage in large and remote areas using unmanned aerial vehicles (UAVs). In this approach, drones capture aerial images and convolutional neural network (CNN) models are used to detect waste from the captured images. [13] the authors proposed a transfer learning-based CNN model to detect garbage in urban environments. The methodology focuses on deep learning classification of urban waste images using pre-trained models.[2] This paper develops A smart garbage monitoring system using machine learning and edge

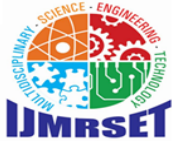

International Journal of Multidisciplinary Research in Science, Engineering and Technology (IJMRSET)

(A Monthly, Peer Reviewed, Refereed, Scholarly Indexed, Open Access Journal)

computing technologies. The system collects sensor data and processes it locally through mobile edge computing along with image analysis to evaluate urban street cleanliness. [4] the authors proposed a smart waste monitoring system that uses ultrasonic sensors to measure the garbage level inside dustbins. The system provides real-time monitoring of bin fill levels and sends alerts using IoT technology to improve urban waste collection efficiency.

[5] C. Manivannan et al. focuses on using deep learning techniques to detect garbage and optimize waste collection routes. The research integrates image processing methods with spatial clustering and UAV imagery to map dustbin locations and garbage accumulation.[14] This paper proposed a real-time garbage detection system using YOLO-based deep learning algorithms. The system uses YOLOv5 and YOLOv8 models to accurately detect full or overflowing bins through camera- based monitoring.[20] The system uses sensors to monitor garbage levels in bins in real time. Data collected from bins is transmitted through IoT modules to a cloud platform for storage and analysis. A centralized dashboard allows authorities to monitor bin status remotely and make decisions efficiently. [3] The study discusses the use of sensors, microcontrollers, and communication modules for real time waste monitoring. It highlights how automation helps improve efficiency in smart city waste management. [12] The system collects data and sends it to a cloud platform for monitoring and analysis. It enables real-time tracking of waste levels without manual inspection.

[7] In this paper, the ultrasonic sensor continuously measures the distance between the waste and the top of the bin to determine the fill level. This data is transmitted to a mobile application, allowing users and municipal authorities to easily track the status of the bin from anywhere. [8] In this paper, the sensors detect when the bin reaches its maximum capacity and automatically send notifications to the concerned authorities. This real-time alert system helps in improving the response time of waste collection services and prevents overflow of garbage. [19] the authors developed an IoT-enabled smart bin using an Arduino microcontroller, a Wi-Fi module, and an ultrasonic sensor to monitor garbage levels in real time. The ultrasonic sensor measures the fill level of the bin and sends the data to the Arduino, which processes and transmits it through the Wi-Fi module to an online platform.[11] Nazif et al. developed a system that captures images of waste items and processes them using trained deep learning models to accurately identify categories such as biodegradable, recyclable, and non- recyclable waste. [17] This system uses image recognition techniques to analyze waste and classify it into multiple categories. This enables automatic sorting of waste in smart bins without manual intervention.

[6] Dodke et al. designed to monitor garbage levels and gas sensors to detect harmful gases produced by waste materials. The ultrasonic sensor continuously measures the fill level of the bin, while the gas sensor identifies toxic gases such as methane and carbon monoxide generated from decomposing waste. [1] The system collects real-time data on garbage levels, temperature, and environmental conditions from smart bins. This data is processed using artificial intelligence algorithms to analyze patterns and predict when bins are likely to become full. [18] In this paper, the Ultrasonic sensors detect bin fill levels and send data to a cloud/server for real-time monitoring. The system provides alerts when bins are full, ensuring timely waste collection. It is low-cost and efficient but depends on stable internet connectivity. [9] K. Sivapriya et al. proposed a smart bin system integrated with a mobile application for efficient waste management. The system uses sensors to monitor garbage levels in real time. [15] The system measures the garbage level inside bins and sends data to a cloud platform. It enables real-time monitoring and basic data analysis. The approach is simple, low-cost, and easy to implement. It helps reduce overflow and improves waste collection efficiency. However, it is limited to basic bin-level monitoring without advanced features like segregation or AI.

III. METHOD

The proposed Autobin system is an IoT-based smart waste management solution designed to improve efficiency and hygiene in garbage collection. The system uses an ultrasonic sensor to continuously monitor the fill level of the dustbin by measuring the distance between the sensor and the garbage surface. In addition to level detection, a load cell sensor is used to measure the weight of the waste accumulated in the bin, providing more accurate information about the bin's capacity. These sensors work together to determine the real-time status of the bin, such as empty, partially filled, or completely full, ensuring reliable monitoring.



International Journal of Multidisciplinary Research in Science, Engineering and Technology (IJMRSET)

(A Monthly, Peer Reviewed, Refereed, Scholarly Indexed, Open Access Journal)

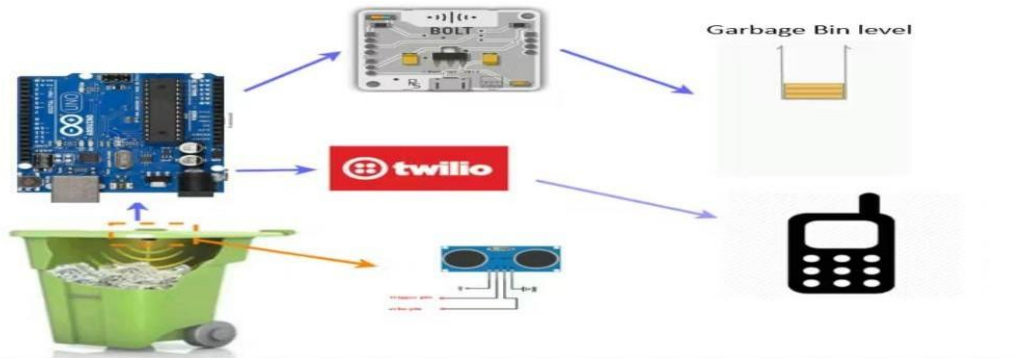

Figure 1: Block diagram of waste collection and alert system

From figure 1, The system is an IoT-based smart waste collection and alert solution designed to improve waste management efficiency. It incorporates an ultrasonic sensor to monitor the fill level of the garbage bin and a load cell sensor to measure the weight of the waste. Both sensors continuously collect real-time data and transmit it to the Arduino Uno microcontroller for processing. The microcontroller analyses the sensor inputs and determines the current status of the bin based on predefined threshold values. The bin status is classified as empty, partially filled, or completely filled. When the waste level or weight exceeds the set limit, the system automatically triggers an alert. This alert is sent through a communication platform such as Twilio to a mobile device, notifying the concerned personnel. The system enables timely waste collection, reduces manual monitoring, prevents overflow, and enhances overall cleanliness and operational efficiency.

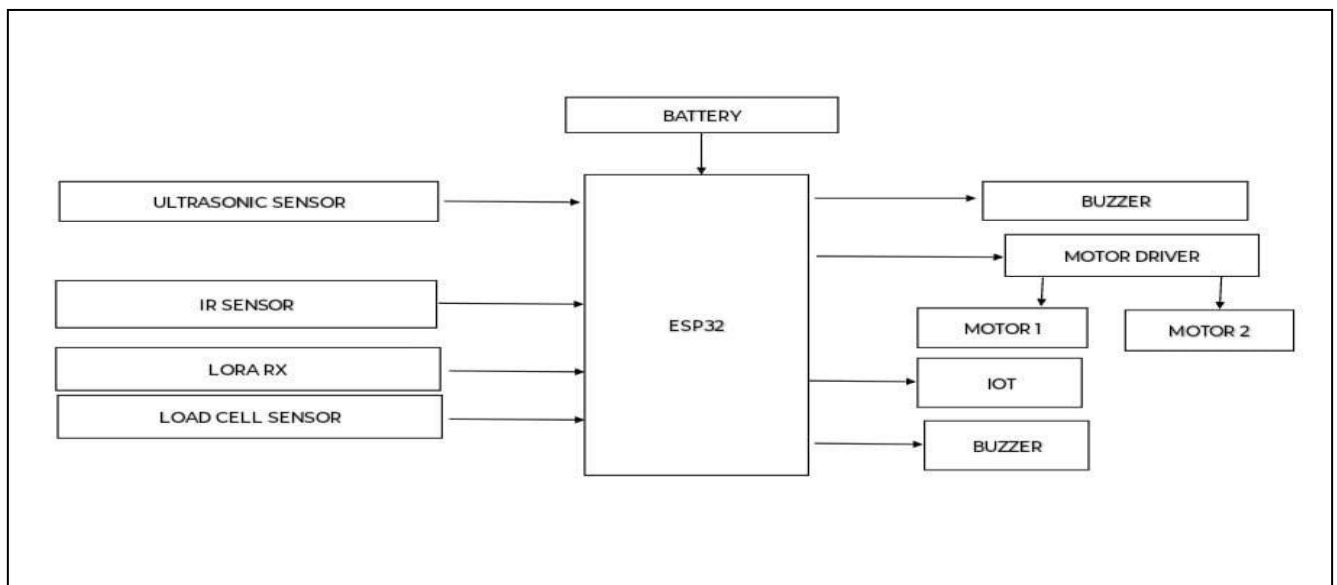

Figure 2: Transmitter Block diagram

From figure 2, The transmitter unit is designed around the ESP32 microcontroller, which serves as the central processing and control component of the system. It interfaces with multiple sensors, including an ultrasonic sensor, IR sensor, and load cell sensor, to acquire real-time data. The ultrasonic sensor measures the fill level of the waste bin, while the load cell sensor determines the weight of the collected waste. The IR sensor facilitates object detection and assists in system activation and control. A LoRa receiver module is incorporated to enable reliable long-range wireless communication. All incoming sensor data is processed by the ESP32 to evaluate the operational condition of the system. The entire unit is powered by a battery, ensuring continuous and stable operation. Based on the processed data, the



International Journal of Multidisciplinary Research in Science, Engineering and Technology (IJMRSET)

(A Monthly, Peer Reviewed, Refereed, Scholarly Indexed, Open Access Journal)

ESP32 generates control signals for output components such as buzzers and motor drivers. The motor driver regulates the operation of two motors, enabling mechanical movement and system functionality. Additionally, the processed information is transmitted to an IoT platform for real-time monitoring, data logging, and alert notification.

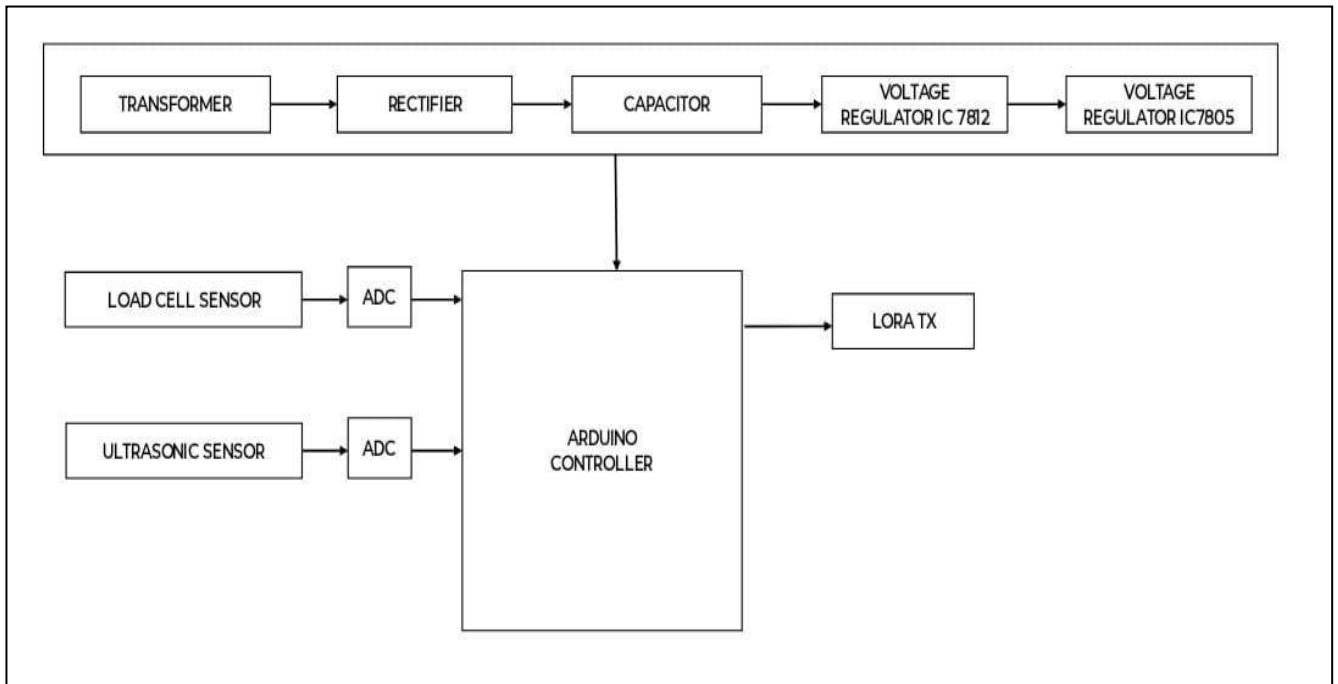

Figure 3: Receiver Block diagram

From figure 3, At the receiver side, the LoRa receiver (LoRa RX) captures the transmitted data and forwards it to an ESP32 microcontroller for further processing and decision-making. The ESP32 acts as the central control unit, analyzing the received data based on predefined threshold values for garbage level and weight. When the bin reaches a critical condition, the ESP32 activates a motor driver connected to a gear motor, enabling automatic movement or rotation of the bin for efficient waste handling. Additionally, a buzzer is integrated into the system to provide immediate local alerts, notifying nearby users when the bin is full.

Furthermore, the system incorporates IoT connectivity using the ESP32's built-in Wi-Fi capability to send real-time notifications to authorized personnel through mobile or web-based applications. The collected data can also be uploaded to a cloud platform, where it is stored, analyzed, and visualized for continuous monitoring. This centralized system allows municipal authorities to track multiple garbage bins remotely, analyze waste generation patterns, and plan optimized collection routes, thereby reducing operational costs and improving efficiency. Overall, the proposed methodology minimizes manual intervention, prevents overflow conditions, enhances sanitation, and supports the development of smart, sustainable, and technology-driven waste management systems.

IV. RESULT AND DISCUSSION

The implemented smart waste management system successfully demonstrated efficient real-time monitoring of garbage levels and weight using ultrasonic and load cell sensors. The system was able to accurately detect the fill status of the dustbin and classify it into different levels such as empty, partially filled, and full. The integration of Arduino Uno and ESP32 controllers ensured reliable data processing and decision making, while the LoRa communication modules provided stable long-range data transmission with minimal power consumption.



International Journal of Multidisciplinary Research in Science, Engineering and Technology (IJMRSET)

(A Monthly, Peer Reviewed, Refereed, Scholarly Indexed, Open Access Journal)

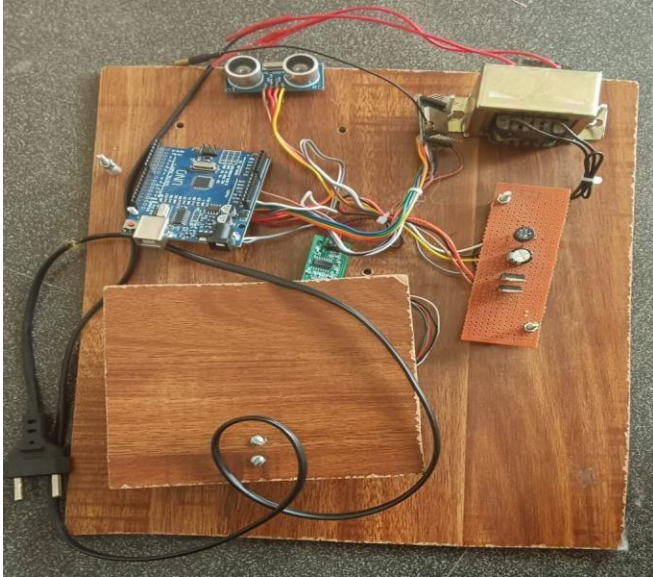

Figure 4: Prototype for Dustbin robot

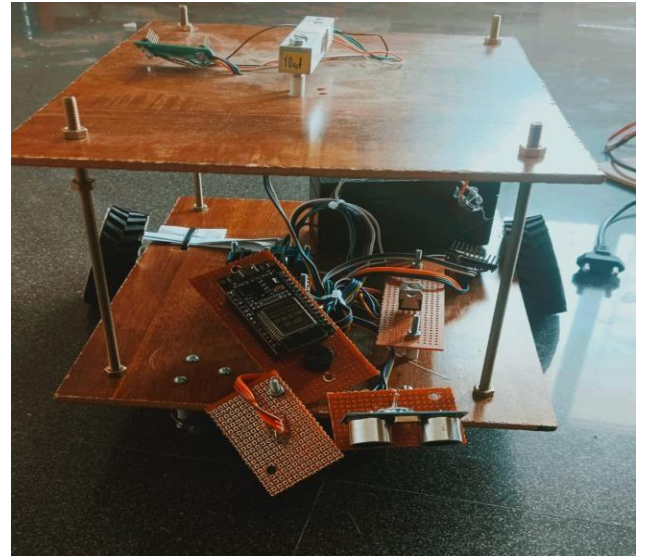

Figure 5: Prototype for Main Robot

From figure 4, The Dustbin Robot Prototype is an intelligent waste collection unit designed to improve cleanliness and efficiency in waste management systems. It is equipped with ultrasonic sensors to detect the garbage level inside the bin and a load cell to measure the weight of the waste. When the bin reaches a certain threshold, the system automatically sends data to the main robot using wireless communication such as LoRa or Wi-Fi. The dustbin also includes a motorized mechanism for opening and closing the lid, ensuring a hygienic and touch-free operation. This prototype helps in reducing manual effort, preventing overflow, and maintaining a clean environment

From figure 5, The Main Robot acts as the central control and waste collection unit in the system. It receives real-time data from multiple dustbin robots and navigates to the filled bins for garbage collection. The robot is powered by a microcontroller like Arduino or ESP32 and uses motor drivers and gear motors for movement and operation. It is capable of autonomous navigation and can follow predefined paths or signals to reach the destination. Once it collects the waste, it transports it to a designated disposal area. This robot enhances automation, reduces human involvement, and ensures efficient waste management in smart environments.

The results indicate that the system significantly reduces manual effort and minimizes the chances of bin overflow. Compared to traditional waste collection methods, the proposed system improves operational efficiency, enhances cleanliness, and supports better resource management. The use of low-power communication technologies like LoRa also makes the system suitable for large-scale deployment in smart cities and remote areas. However, certain challenges such as sensor calibration, environmental factors affecting sensor accuracy, and dependency on network connectivity were observed. Despite these limitations, the system proves to be a reliable and scalable solution for modern waste management. Overall, the proposed system contributes to improved sanitation, optimized waste collection processes, and the development of sustainable and smart urban environments.

V. CONCLUSION

The proposed smart waste management system utilizes ultrasonic and load cell sensors to accurately monitor the fill level and weight of the dustbin, ensuring efficient and timely waste management. The ultrasonic sensor measures the distance between the garbage and the top of the bin, while the load cell sensor determines the weight of the accumulated waste. The collected data is processed using an Arduino Uno microcontroller for initial analysis, and an ESP32 controller is used for advanced processing and control operations. Based on predefined threshold values, the system controls a motor driver and gear motor to automate bin movement and improve waste handling efficiency. The LoRa TX and RX modules enable long-range and low-power wireless communication, allowing real-time transmission of sensor data between units. Additionally, a buzzer provides immediate local alerts when the bin reaches its maximum

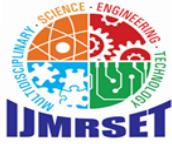

International Journal of Multidisciplinary Research in Science, Engineering and Technology (IJMRSET)

(A Monthly, Peer Reviewed, Refereed, Scholarly Indexed, Open Access Journal)

capacity. The system is further integrated with IoT technology to send real-time notifications to authorities through mobile or web platforms, thereby reducing manual effort, preventing overflow, and enhancing overall waste management efficiency.

REFERENCES

- [1] Al-Qurashi et al. (2025) developed an “AI-based waste management system” integrating IoT sensors for smart decision making.
- [2] A. V. Aswini et al. (2023) developed an ML-based smart garbage collection system with edge computing. It reduces latency and enables real-time processing. However, it needs additional edge infrastructure
- [3] Abhishek et al. (IJERT, 2025) presented a review of IoT-based smart waste management systems using embedded technologies. The study highlights sensor-based monitoring and automation in smart cities. However, integration complexity and cost remain challenges.
- [4] B. Girhepunje et al. (2025) developed an IoT-based smart garbage monitoring system using ultrasonic sensors and GSM communication. It enables real-time bin level tracking through the Blynk platform. The system is low-cost but depends on network reliability.
- [5] C. Manivannan et al. (2024) proposed a deep learning-based waste monitoring system with UAV imagery and route optimization. It improves efficiency in waste collection and reduces fuel usage. However, it requires advanced infrastructure like drones.
- [6] Dodke et al. (2026) designed an “IoT-based system using ultrasonic and gas sensors” for monitoring waste level and environmental conditions.
- [7] Ilyas et al., “Design of Smart Dustbin for Real-Time Waste Monitoring Using IoT,” International Journal of Advanced Research in Computer Science, 2021S.
- [8] Kumar et al., “Smart Waste Management System Using IoT Sensors,” International Journal of Engineering and Advanced Technology, 2021.
- [9] K. Sivapriya et al. (IJERT, 2024) proposed a smart bin system integrated with a mobile application. It monitors bin levels and provides alerts for timely collection. The system improves efficiency but depends on app connectivity.
- [10] Labade et al., “Smart Garbage Monitoring System Using IoT,” International Journal of Engineering Research and Technology, 2020.
- [11] Nafiz et al. (2023) implemented automatic waste Ilyas et al., “Design of Smart Dustbin for Real-Time Waste Monitoring Using IoT,” International Journal of Advanced Research in Computer Science, 2021segregation using convolutional neural networks for intelligent.
- [12] Pavithra et al. (2023) developed an automated waste management system using IoT and GSM for remote monitoring and alert.
- [13] S. A. Arif & A. M. Ashir (2024) proposed a CNN-based garbage detection model using transfer learning. It improves accuracy and reduces training time. Performance depends on dataset quality
- [14] Skip-YOLO (2023) enhances domestic garbage detection using improved YOLO architecture. It provides better classification of similar waste types. The model requires large datasets and high training effort.
- [15] Snigdha et al. (Atlantis Press, 2023) developed an IoT-based smart waste management system using ultrasonic sensors. It enables real-time monitoring and cloud data analysis. The system is simple but limited to basic bin-level detection.
- [16] Srivastava and Venkat (2023) introduced an IoT-enabled smart bin system. It allows real-time monitoring of waste levels. The system improves collection planning and efficiency. It helps reduce operational costs. It is useful in modern smart city environments.
- [17] V. Verma et al. (2022) used UAVs and CNN models for garbage detection in large areas. It enables remote monitoring and wide coverage. The system depends on drone regulations and weather conditions.
- [18] White et al. (2020) introduced a deep learning-based waste classification model to improve recycling accuracy
- [19] Yadav et al., “IoT-Based Garbage Monitoring System Using Arduino and Wi-Fi,” International Journal of Scientific Research in Engineering and Management, 2021.
- [20] Yousef et al. (2022) proposed a smart waste management system using IoT and cloud computing.



INTERNATIONAL
STANDARD
SERIAL
NUMBER
INDIA



INTERNATIONAL JOURNAL OF MULTIDISCIPLINARY RESEARCH IN SCIENCE, ENGINEERING AND TECHNOLOGY

| Mobile No: +91-6381907438 | Whatsapp: +91-6381907438 | ijmrset@gmail.com |

www.ijmrset.com